



Quarter Pony Association

2018 On-Line World Show

Submittals Open: May 1, 2018

Entries Close: September 30, 2018

Open to all registered Stock-Type ponies. Some eligible registries include: IQPA, NQPA, APPR, POAC, American QPA and Australian QPA. Also eligible are ponies 14.2 hands (144cm) or smaller and registered with: AQHA, ApHC, NFAQHA and APHA. You do not need to be a QPA member to participate and earn the cash payout. However, only QPA members will earn year-end awards and titles. Please check it out: www.quarterponyassociation.com.

Show Manager: Tami Platt

tamiplatt@comcast.net

503.459.8007

Class List

Halter

- 1 Halter Weanlings / Yearlings
- 2 Halter Mares 2 & Over
- 3 Halter Stallions / Geldings 2 & Over

Showmanship

- 4 Showmanship Youth 8 & Under
- 5 Showmanship Weanlings / Yearlings
- 6 Showmanship Open

English Pleasure

- 7 English Pleasure Jr. Pony (4 & Under)
- 8 English Pleasure Sr. Pony (5 & Over)

English Equitation

- 9 English Equitation Youth (17 & Under)
- 10 English Equitation Adult (18 & Over)

Hunter Hack

- 11 Hunter Hack Open

Western Pleasure

- 12 Western Pleasure Jr. Pony (4 & Under)
- 13 Western Pleasure Sr. Pony (5 & Over)

Western Equitation

- 14 Western Equitation Youth (17 & Under)
- 15 Western Equitation Adult (18 & Over)

Driving

- 16 Driving Open

Trail In-Hand

- 17 In-Hand Trail Weanlings / Yearlings

Trail Ridden

- 18 Riding Trail

Triple judged! Three times the points for one low entry! Class fees are \$18 per class. Placings through 10th, payout (50%) through 5th. PayPal only. QPA reserves the right to split or combine classes as needed. A detailed description of each class, patterns and rules can be found on the QPA website: www.quarterponyassociation.com. We highly encourage all entries to become members of QPA as this family oriented organization has many benefits.

All proceeds go towards QPA Members' Year End Awards.



Quarter Pony Association

On-Line World Show

Submittals Open: May 1, 2018

Entries Close: September 30, 2018

Pony Name (one per entry): _____

Sex: _____ Age as of 1/1/18: _____ Registry (ies): _____

Owner: _____ Exhibitor: _____

Owner Contact Email: _____ Phone: _____

PayPal Paid entries must arrive no later than Sunday 9/30/18.

Email Entry: TamiPlatt@Comcast.net

PayPal: President@QuarterPonyAssociation.com \$18 each Class: \$ _____

List class numbers: _____

How to submit an entry:

- Send in your entry form via E-mail, TamiPlatt@Comcast.net, and submit your entry fees via PayPal: President@QuarterPonyAssociation.com. All winnings will be distributed by PayPal only.
- Include a copy of your pony's registration papers. A clear photograph or scanned image is just fine. (IQPA ponies do not need to send in copies)
- Record a high quality video of your pony performing the required pattern for the class.
 - Do not edit the video in any way – including titles, graphics, music, etc.
 - Keep the pony and exhibitor in the video frame at all times.
- Upload the video.
 - You have two options: www.youtube.com or www.facebook.com: QPA 2018 Online World Show.
 - Name the video you pony's Full Registered Name, 2018 World Show and Class number. For example: Smokin Doubledutch 2018 World Show #17 Open Driving.
 - You may "mute" the video or turn off the sound. Otherwise, do not edit the video in any way.
- Helpful hints:
 - Practice (your competition is!) You don't have to turn in the first recording, or even the 15th recording.
 - Have great lighting. Outdoors or in a well-lit arena will serve you well.
 - Don't wait!! Some ponies are getting fuzzy by the end of September. A smooth and shiny coat will place higher than a fuzzy coat.
 - Read the rules. (The judges do!) All the information you need is on the QPA website: www.quarterponyassociation.com.
 - Join QPA! QPA members enjoy some great benefits. All points from the QPA 2018 Online World Show apply to QPA Year End Awards as well as Titles such as Registry of Merit and Superior Registry.
- Questions? Contact the Show Manager: Tami Platt at tamiplatt@comcast.net or 503.459.8007



Quarter Pony Association

2018 On-Line World Show

Submittals Open: May 1, 2018

Entries Close: September 30, 2018

Halter – Rules and Pattern (Classes #1- #3)

The purpose of the class is to preserve Quarter Pony type by selecting well-mannered individuals in the order of their resemblance to the breed ideal and that are the most positive combination of balance, structural correctness, and movement with appropriate breed and sex characteristics and adequate muscling. While it could be assumed that most ponies with several years' seasoning and past performance have acceptable conformation, the goal in selection should always be to find the best conformed pony possible that represents the perfect example of the Quarter Pony breed standard.

The ideal Quarter Pony shown at halter is a pony that is generally considered to possess the following characteristics:

- Balance, structural correctness, breed and sex characteristics, and degree of muscling. Of the four, balance is the single most important, and refers to the structural and aesthetic blending of body parts. Balance is influenced almost entirely by skeletal structure.
- The pony should possess eye appeal that is the result of a harmonious blending of an attractive head; refined throat latch; well-proportioned, trim neck; long, sloping shoulder; deep heart girth; short back; strong loin and coupling; long hip and croup; and well-defined and muscular stifle, gaskin, forearm and chest.
- These characteristics should be coupled with straight and structurally correct legs and feet that are free of blemishes. The pony should be a balanced athlete that is muscled uniformly throughout.
- Correct bite.
- All stallions 2 years old and over shall have two visible testicles.
- Having a resemblance to a non-quarter breed is considered a fault.
- Judge(s) may choose to fault or disqualify lame and / or disruptive ponies.

Helpful hints:

- Pony should be properly fitted for the show arena and handler properly dressed.
- Pony may be shown either in all Western Attire/Tack or all English Attire/Tack.
- Be sure the entire pony is captured in the video at all times.
- Camera must remain rolling for the whole session.
- Here is a video that may help: [Helpful Hints](#)

Photo examples. 2017 World Champion Mare – Skippers Peppy Lena, owned by Wendy Loper.





Quarter Pony Association

2018 On-Line World Show

Submittals Open: May 1, 2018

Entries Close: September 30, 2018

Halter – Rules and Pattern (Classes #1- #3)

Pattern:

- Start with the pony set squarely facing the judge (camera person) about 15 ft. / 5m away.
- Walk straight to the judge (camera person).
- As you pass the judge (camera person), they will step to the side and let you trot past.
- Judge (camera person) should see your pony trot straight away, approximately 15 ft. / 5m.
- Turn a ½ circle to the right and straight until you are even with the judge (camera person).
- Set up squarely for inspection. Have the judge (camera person) walk around your pony showing all angles of the pony.
- Include the following six photos with your submittal:
 - Left profile
 - Right profile
 - Rear
 - Front
 - Bite
 - Two distended testicles (for stallions aged two years and over- Class #3)

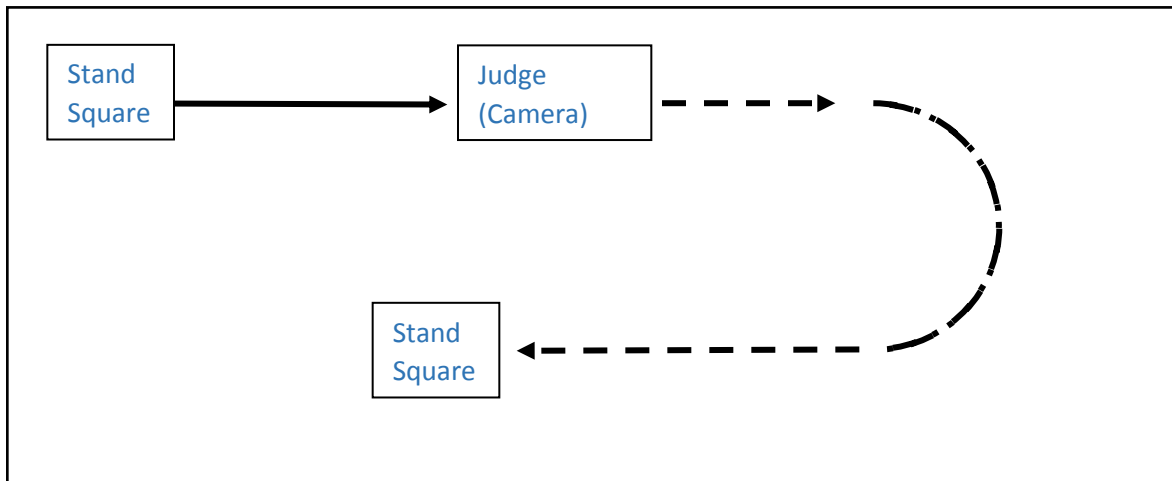

Upload your video

- You have two options: www.youtube.com or www.Facebook.com (QPA 2018 Online World Show).
- Name the video you pony's Full Name, 2018 World Show and Class number. For example: Skippers Peppy Lena 2018 World Show #2 Halter Mares.
- You may "mute" the video or turn off the sound. Otherwise, do not edit the video in any way.



Quarter Pony Association

2018 On-Line World Show

Submittals Open: May 1, 2018

Entries Close: September 30, 2018

Showmanship – Rules and Patterns (Classes #4 -#6)

Class will be judged on each exhibitor's ability to properly groom, fit, and show their Pony at Halter. Pony and exhibitor can be fitted in either English or Western Tack / Attire.

Video:

- You have two options for your video. You can have your camera be the judge, or you can set your camera up and have someone else act as your judge. Both perspectives are acceptable.
- The exhibitor should continue showing the pony through the entire video with no stops or starts in the video.
- Examples:
 - Judge and Camera as the same: [2017 Yearling Showmanship Salix Golden Legacy Eagle](#)
 - Camera separate from Judge: [2017 10 & Under Showmanship](#)

Exhibitor:

- Exhibitor should be neat in personal appearance, including attire and confidence, while demonstrating the abilities necessary to lead and handle the pony smoothly and precisely through the requested pattern with efficiency.
- Exhibitor should perform the work quickly and smoothly.
- Class shall be judged as follows:
 - 10% on Exhibitor
 - 30% on the proper fitting and grooming of Pony
 - 60% on the performance of Showmanship.
- If exhibitor is under age 8, a helper can be present nearby for safety and support, but exhibitor must do showing, leading and handling performance.
- The Class patterns to be used are provided along with this Class description.
- The exhibitor should have good posture and move in side holding the lead shank in the right hand near the halter with the tail of the lead held in the left hand.
- When leading, the exhibitor should be positioned between the eye and the mid-point of the neck, referred to as the leading position.
- When executing a back, the exhibitor should turn from the leading position to face toward the haunch with the pony moving backward.
- When setting up the pony for inspection, the exhibitor should stand angled toward the pony in a position between the head and shoulder.
- The exhibitor should maintain a position that is safe for themselves and the judge.
- The position of the exhibitor should not block the judge's view of the pony and should allow the exhibitor to maintain awareness of the judge's position at all times.
- When moving around the pony, the exhibitor should change sides in front of the pony with minimal steps and should assume the same position on the right side of the pony that he had on the left side. Use The Quartering Method.
- At no time should the exhibitor stand directly in front of the pony.
- The exhibitor should not touch the pony with hands or feet.

Appearance of Pony:

- Tack should fit properly and be neat, clean and in good condition.
- The pony's body condition and overall fitness will be assessed.

- The hair coat should be clean, and well-groomed.
- The mane, tail, forelock and wither hair may not contain ornaments (ribbons or bows), but may be banded.
- The length of mane and tail may vary as long as they are neat, clean and free of tangles.
- The mane should be even in length or may be roached, but the forelock and tuft over the withers must be left.
- The bridle path, eyebrows and long hair on the head and legs may be clipped.
- A sparse mane and tail shall not be discriminated against.
- Hooves should be properly trimmed and if shod, the shoes should fit correctly and clinches should be neat.
- Hooves must be clean and may have clear polish or clear hoof dressings applied or be shown naturally.

Performance:

- The pony should lead, stop back, turn and perform willingly.
- Pony should be led directly to and away from the judge in a straight line and as instructed in the pattern.
- The pony's head and neck should be in a straight line with its body.
- Pony should stop with its body in a straight position, and when backed should readily have its head and neck in a straight line with its body.
- When turning the pony 90 degrees or less, the pony should be turned by leading. On turns of greater than 90 degrees, the ideal turn consists of the pony pivoting on the inside hind leg while stepping across and in front of the opposite leg.
- An exhibitor should not be penalized if the pony performs a pivot on the outside hind leg, but an exhibitor whose pony performs the pivot correctly should receive more credit.
- The pony should be set up quickly with the feet squarely underneath the body.
- The exhibitor does not have to reset a pony that stops square.

Faults:

- Poorly groomed or conditioned pony.
- Dirty, ragged, or poorly or ill-fitted halter or lead.
- Poor or improper position of exhibitor.
- Excessive stiff or unnatural movement around pony or when leading.
- Continuous holding of the chain part of the lead, or lead shank tightly coiled around hand or dragging the ground.
- Changing hands or placing both hands on the lead.
- Complete failure to move around pony by exhibitor and obstructing judge's view.
- Exhibitor touching the pony with hands or feet.
- Standing directly in front of the pony.
- Changing or missing any of the maneuvers in pattern.
- Knocking over a cone or prop.
- Severe disobedience including rearing or pawing, striking, kicking, or pony continuously circling the exhibitor.

Disqualifications:

- Loss of control of pony that endangers exhibitor, other ponies or exhibitors, or judge, including the pony escaping from the exhibitor.
- Willful abuse.
- Excessive schooling or training or use of artificial aids.

Upload your video

- You have two options: www.youtube.com or www.Facebook.com (QPA 2018 Online World Show).
- Name the video you pony's Full Name, 2018 World Show and Class number. For example: Skippers Peppy Lena 2018 World Show #6 Showmanship.
- You may "mute" the video or turn off the sound. Otherwise, do not edit the video in any way.



Quarter Pony Association

2018 On-Line World Show

Submittals Open: May 1, 2018

Entries Close: September 30, 2018

Showmanship – Rules and Patterns (Classes #4 -#6)

Patterns:

Class #4 – Showmanship Youth 8 & Under

Class #5 – Showmanship Weanlings and Yearlings

- Stand pony square, facing judge. Wait for acknowledgement to start.
- Trot to Judge.
- Set for Inspection.
- After Inspection, perform 180* right haunch turn.
- Walk half way back to start.
- Trot the rest of the way to start.
- Halt at starting point, facing away from Judge.
- Square pony, acknowledge Judge.

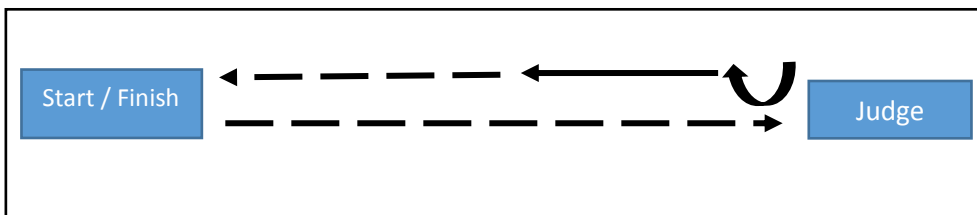

Class #6 – Showmanship Open

- Start pattern facing away from Judge.
- Back one pony length towards Judge.
- Perform 180* left haunch turn.
- Trot on off-side to Judge.
- Set for Inspection
- Perform 240* right haunch turn.
- Walk "V".
- Perform 240* right haunch turn.
- Back one pony length away from Judge.
- Square pony and acknowledge Judge.

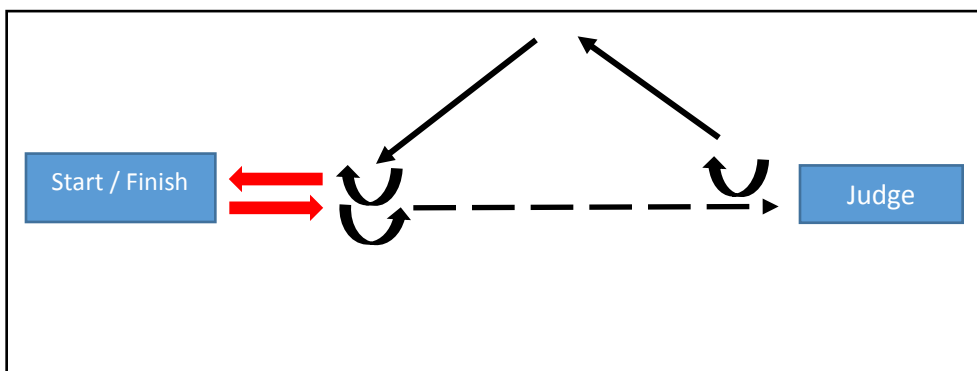



Quarter Pony Association

2018 On-Line World Show

Submittals Open: May 1, 2018

Entries Close: September 30, 2018

English Pleasure – Rules and Patterns (Classes #7 -#8)

Ponies should be suitable to purpose and should move with long, low strides reaching forward with ease and smoothness. Be able to lengthen stride and cover ground with relaxed, free flowing movement, while exhibiting correct gaits that are of the proper cadence. Ponies should be obedient, have a bright expression with alert ears, and should respond willingly to the rider with light leg and hand contact. Ponies should be responsive and smooth in transition. The poll should be level with, or above, the withers to allow proper impulsion behind. The head position should be slightly in front of, or on, the vertical. Pony utilizes the top line by rounding its back and driving evenly off the hind legs with even rhythm and cadence. Soft in the poll, jaw and mouth and is shown with light rein contact. The English Pony creates energy yet stays soft and responsive to his rider. The pony's weight is distributed properly onto its hindquarters and he moves with long, slow strides. This pony has a great degree of suspension, impulsion and elasticity to its movement.

Judging

- This class will be judged 60% on performance and manners; 30% on type, conformation, quality and substance; and 10% on appointments.
- Ponies to be:
 - Shown at a walk, trot and canter both ways of the ring.
 - Back easily and stand quietly.
 - Reversed to the inside away from the rail, at a walk.
 - Extended trot & hand gallop may be added based on Class Type.
- Faults to be scored according to severity:
 - Quick, short, or vertical strides.
 - Being on the wrong lead.
 - Breaking gait.
 - Excessive speed.
 - Failure to take the appropriate gait when called for.
 - Head carried too high or too low. (Too low is a major fault/Too high is minor fault.)
 - Over flexing or straining neck in head carriage so the nose is carried behind the vertical.
 - Excessive nosing out.
 - Failure to maintain light contact with pony's mouth.
 - Stumbling.
 - Pony appearing sullen, dull, lethargic, emaciated, drawn or overly tired.
 - Poor equitation
- Tack
 - In all English classes, an English snaffle (no shanks), Kimberwick, Pelham and/or full bridle (with two reins), all with cavesson nosebands and leather brow bands must be used. A port must be no higher than 1-1/2" (3.8 cm).
 - On broken mouthpieces, the mouthpiece may be two or three pieces. If it is three pieces, a connecting ring must be no larger than 1-1/4" (3.2 cm) outside diameter, or a connecting flat bar must be no longer than 2"(5 cm) and 3/8" (1 cm) to 3/4" (2 cm) measured top to bottom and must lie flat in mouth.
 - If a curb bit is used, the chain must be at least 1/2" (1.3 cm) in width and lie flat against the jaw of the pony.

- All smooth, round, twisted, slow twist, corkscrew, double twisted wire (mouthpieces) and straight bars or solid mouth pieces with a maximum port height of 1-1/2" (3.8 cm) are acceptable.
- Nothing, such as extensions or prongs may protrude below the mouthpiece (bar). All mouthpieces must be a minimum of 5/16" (0.8 cm) in diameter measured 1" (2.5 cm) from the cheek.
- The judge may prohibit the use of bits and equipment he may consider too severe.
- A bit cannot be physically or mechanically changed to increase the severity of its use, and the exhibitor may be eliminated at the discretion of the judge.
- Saddles must be of black and/or brown colors. Hunt seat, Dressage saddles or forward seat type may have an insert on the skirt.
- Saddle pads must be of the classic style and composition. Pads with extensions designed for show numbers are acceptable.
- Optional Equipment
 - Spurs of the unroweled type.
 - Crops or bats.
 - English breast plates.
 - Braiding of mane and/or tail in hunt style.
 - Banding of mane.
- Disqualifications.
 - English bits of any style featuring cathedral, fish back, or donut mouthpiece; rough, sharp material; or mechanically altered bits are illegal and shall be cause for disqualification. In all divisions, if a mouth is found to be bloody, disqualification is at the discretion of the judge.
 - Colored saddle pads.
 - Roweled spurs.
 - Standing or running martingales.
 - Dropped nosebands.
 - Protective boots, leg wraps and /or bandages.
 - Draw reins.

Attire

- Exhibitors must be neatly dressed including:
- Hunt coats of traditional English style and conservative color.
- Breeches (or jodhpurs) of traditional shades of buff, gray or rust
- English tall boots or paddock (Jodhpur) boots of black or brown.
- A tie, choker or rat catcher is required.
- Gloves are optional.
- Black, navy blue, brown or green hunt cap.
- Long hair must be neat and contained in a net or braid.

Upload your video

- You have two options: www.youtube.com or www.Facebook.com (QPA 2018 Online World Show). Name the video you pony's Full Name, 2018 World Show and Class number. For example: A Dash of Dusty 2018 World Show #8 English Pleasure.
- You may "mute" the video or turn off the sound. Otherwise, do not edit the video in any way.



Quarter Pony Association

2018 On-Line World Show

Submittals Open: May 1, 2018

Entries Close: September 30, 2018

English Pleasure – Rules and Patterns (Classes #7 -#8)

Class #7 – English Pleasure Jr. Pony

Class #8 – English Pleasure Sr. Pony

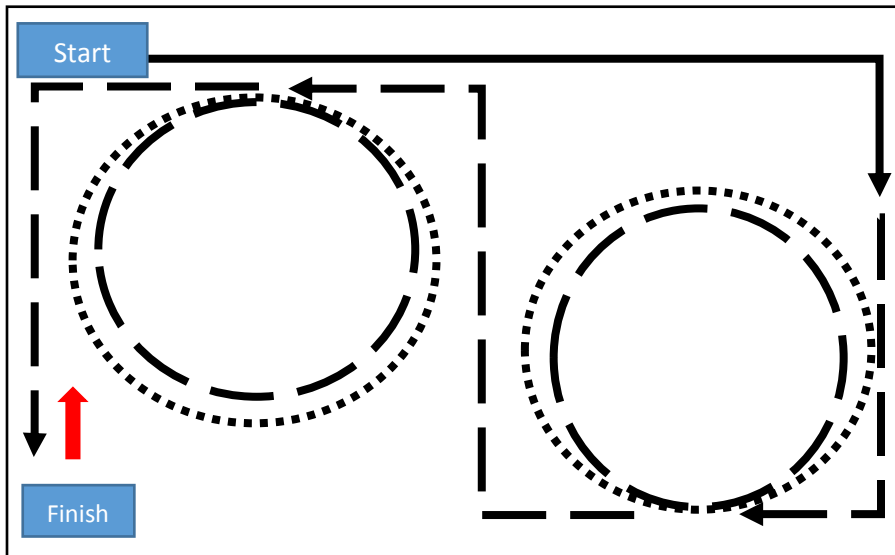

- Start at halt, acknowledge Judge (camera).
- Walk forward along rail and around corner.
- Pick up trot and trot around corner.
- Circle right.
- Pick up canter and circle right.
- Return to trot, turn right, cross arena and turn left.
- Circle left.
- Pick up canter and circle left.
- Return to trot and trot around corner.
- Halt, back one pony length.
- Acknowledge Judge (camera).

Upload your video

- You have two options: www.youtube.com or www.Facebook.com (QPA 2018 Online World Show). Name the video you pony's Full Name, 2018 World Show and Class number. For example: A Dash of Dusty 2018 World Show #8 English Pleasure.
- You may "mute" the video or turn off the sound. Otherwise, do not edit the video in any way.



Quarter Pony Association

2018 On-Line World Show

Submittals Open: May 1, 2018

Entries Close: September 30, 2018

English Equitation – Rules and Patterns (Classes #9 -#10)

Rider to be judged on seat, hands, performance of pony, appointments of pony and rider and suitability of pony to rider. Good hands are paramount. Results as shown by the performance of the pony are NOT to be considered more important than the method used in obtaining them.

Exhibitor

Judging

- This class will be judged 70% on Equitation and performance; and 30% on appointments.
- Ponies to be:
 - Shown at a walk, trot and canter.
 - Back easily and stand quietly.
 - Extended trot & hand gallop may be added based on Class Type.
- Faults to be scored according to severity:
 - Quick, short, or vertical strides.
 - Being on the wrong lead.
 - Breaking gait.
 - Excessive speed.
 - Failure to take the appropriate gait when called for.
 - Head carried too high or too low. (Too low is a major fault/Too high is minor fault.)
 - Over flexing or straining neck in head carriage so the nose is carried behind the vertical.
 - Excessive nosing out.
 - Failure to maintain light contact with pony's mouth.
 - Poor equitation

Tack

- In all English classes, an English snaffle (no shanks), Kimberwick, Pelham and/or full bridle (with two reins), all with cavesson nosebands and leather brow bands must be used. A port must be no higher than 1-1/2" (3.8 cm).
- On broken mouthpieces, the mouthpiece may be two or three pieces. If it is three pieces, a connecting ring must be no larger than 1-1/4" (3.2 cm) outside diameter, or a connecting flat bar must be no longer than 2" (5 cm) and 3/8" (1 cm) to 3/4" (2 cm) measured top to bottom and must lie flat in mouth.
- If a curb bit is used, the chain must be at least 1/2" (1.3 cm) in width and lie flat against the jaw of the pony.
- All smooth, round, twisted, slow twist, corkscrew, double twisted wire (mouthpieces) and straight bars or solid mouth pieces with a maximum port height of 1-1/2" (3.8 cm) are acceptable.
- Nothing, such as extensions or prongs may protrude below the mouthpiece (bar). All mouthpieces must be a minimum of 5/16" (0.8 cm) in diameter measured 1" (2.5 cm) from the cheek.
- The judge may prohibit the use of bits and equipment he may consider too severe.
- A bit cannot be physically or mechanically changed to increase the severity of its use, and the exhibitor may be eliminated at the discretion of the judge.
- Saddles must be of black and/or brown colors. Hunt seat, Dressage saddles or forward seat type may have an insert on the skirt.
- Saddle pads must be of the classic style and composition. Pads with extensions designed for show numbers are acceptable.

Optional Equipment

- Spurs of the unroweled type.
- Crops or bats.

- English breast plates.
- Braiding of mane and/or tail in hunt style.
- Banding of mane.

Disqualifications.

- English bits of any style featuring cathedral, fish back, or donut mouthpiece; rough, sharp material; or mechanically altered bits are illegal and shall be cause for disqualification. In all divisions, if a mouth is found to be bloody, disqualification is at the discretion of the judge.
- Colored saddle pads.
- Roweled spurs.
- Standing or running martingales.
- Dropped nosebands.
- Protective boots, leg wraps and /or bandages.
- Draw reins

Exhibitor

Attire

- Rider should have a workmanlike appearance, seat and hands light and supple, conveying the impression of complete control should any emergency arise.
- Exhibitors must be neatly dressed including:
 - Hunt coats of traditional English style and conservative color.
 - Breeches (or jodhpurs) of traditional shades of buff, gray or rust
 - English tall boots or paddock (Jodhpur) boots of black or brown.
 - A tie, choker or rat catcher is required.
 - Gloves are optional.
 - Black, navy blue, brown or green hunt cap.
 - Long hair must be neat and contained in a net or braid.

Hand Position

- Hands should be over and in front of pony's withers, knuckles 30 degrees inside the vertical, hands slightly apart and making a straight line from the pony's mouth to the rider's elbow.
- The method of holding reins is optional and the bight of the reins may fall on either side. However, all reins must be picked up at the same time.

Basic Position

- The eyes should be up and shoulders back.
- Toes should be at an angle best suited to rider's conformation: ankles flexed in, heels down, calf of leg in contact with pony and slightly behind girth.
- Iron should be on the ball of the foot and must not be tied to the girth.
- At the walk, the body should be vertical.
- Sitting trot and canter, body slightly in front of the vertical
- Posting trot, inclined forward 20 degrees
- Hand galloping inclination should be 30 degrees, with only the legs in contact with the saddle (two-point contact).

Mounting and Dismounting

- To mount, take up reins in left hand and place hand on withers. Grasp stirrup leather with right hand and insert left foot in stirrup, toe in girth and mount.
- To dismount, rider may either step down or slide down. The size of the rider must be taken into consideration.

Upload your video

- You have two options: www.youtube.com or www.Facebook.com (QPA 2018 Online World Show).
- Name the video you pony's Full Name, 2018 World Show and Class number. For example: TG Cookies N Cream 2018 World Show #10 English Equitation.
- You may "mute" the video or turn off the sound. Otherwise, do not edit the video in any way.



Quarter Pony Association

2018 On-Line World Show

Submittals Open: May 1, 2018 Entries Close: September 30, 2018

English Equitation – Rules and Patterns (Classes #9 -#10)

Class #9 – English Equitation Youth 17 & Under

Class #10 – English Equitation Adult 18 & Over

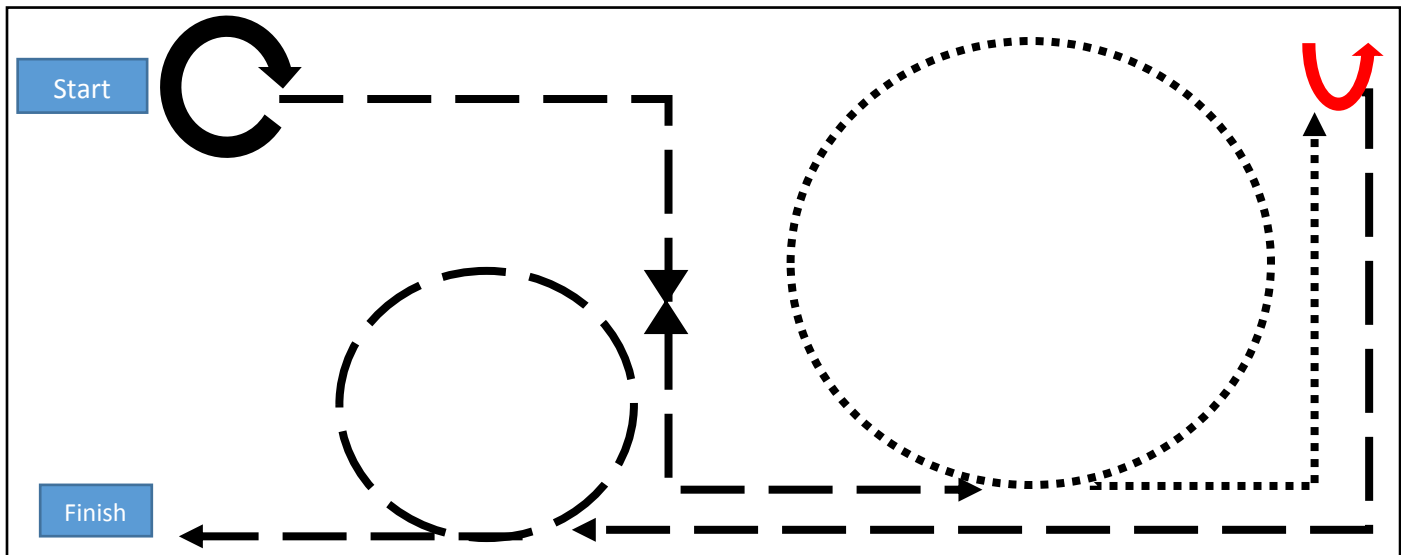

- Start at halt, acknowledge Judge (camera).
- Perform 360* right haunch turn.
- Proceed working trot on the left (correct) diagonal.
- Turn right, change diagonal, turn left.
- Pick up the working canter, left lead.
- Perform a large circle to the left.
- Proceed straight around corner and to the rail and halt.
- Back pony ½ circle.
- Drop irons and proceed at a seated trot to and around corner.
- Collect irons and continue seated trot down rail.
- Pick up the working trot on the left (correct) diagonal and perform a small circle to the right.
- Proceed straight ahead and halt facing rail.
- Dismount, address your pony and acknowledge Judge (camera).

Upload your video

- You have two options: www.youtube.com or www.Facebook.com (QPA 2018 Online World Show).
- Name the video you pony's Full Name, 2018 World Show and Class number. For example: TG Cookies N Cream 2018 World Show #10 English Equitation.
- You may "mute" the video or turn off the sound. Otherwise, do not edit the video in any way.



Quarter Pony Association

2018 On-Line World Show

Submittals Open: May 1, 2018

Entries Close: September 30, 2018

Hunter Hack Open – Rules and Pattern (Class #11)

The Hunter must be free and forward moving in all paces, and be straight in its action. A flat stilted action is unacceptable for a Hunter, but some knee action can be displayed. It must be sound of wind and limb. Unsoundness negates the Hunter's ability to carry out a full day's hunting.

Hunter Hack consists of two jumps. The workout for this class should be free flowing and forward moving, with the horse covering the ground in all paces. The workout should be kept simple and include a walk, trot, canter and a gallop. The pony, when asked to halt, must come down through the paces calmly, obediently and stand still quietly without fidgeting.

Equipment needed

- Four jump standards (at least 24in / 61cm tall)
- Four jump poles
- Measuring tape (at least 40ft. / 12m long)

Tack

- In all English classes, an English snaffle (no shanks), Kimberwick, Pelham and/or full bridle (with two reins), all with cavesson nosebands and leather brow bands must be used. A port must be no higher than 1-1/2" (3.8 cm).
- On broken mouthpieces, the mouthpiece may be two or three pieces. If it is three pieces, a connecting ring must be no larger than 1-1/4" (3.2 cm) outside diameter, or a connecting flat bar must be no longer than 2"(5 cm) and 3/8" (1 cm) to 3/4" (2 cm) measured top to bottom and must lie flat in mouth.
- If a curb bit is used, the chain must be at least 1/2" (1.3 cm) in width and lie flat against the jaw of the pony.
- All smooth, round, twisted, slow twist, corkscrew, double twisted wire (mouthpieces) and straight bars or solid mouth pieces with a maximum port height of 1-1/2" (3.8 cm) are acceptable.
- Nothing, such as extensions or prongs may protrude below the mouthpiece (bar). All mouthpieces must be a minimum of 5/16" (0.8 cm) in diameter measured 1" (2.5 cm) from the cheek.
- The judge may prohibit the use of bits and equipment he may consider too severe.
- A bit cannot be physically or mechanically changed to increase the severity of its use, and the exhibitor may be eliminated at the discretion of the judge.
- Hunt Seat Saddles must be of black and/or brown colors. Saddle may have an insert on the skirt.
- Saddle pads must be of the classic style and composition. Pads with extensions designed for show numbers are acceptable.

ATTIRE

- Exhibitors must be neatly dressed including:
 - Hunt coats of traditional English style and conservative color.
 - Breeches (or jodhpurs) of traditional shades of buff, gray or rust
 - English tall boots or paddock (Jodhpur) boots of black or brown.
 - A tie, choker or rat catcher is required.
 - Gloves are optional.
 - Long hair must be neat and contained in a net or braid.
 - An ASTM / SEI approved helmet is required for this class.

Optional Equipment

- Spurs of the unroweled type.
- Crops or bats.
- English breast plates.
- Braiding of mane and/or tail in hunt style.

- Standing or running martingales.
- Dropped nosebands.
- Protective boots, leg wraps and bandages.

Disqualifications

- English bits of any style featuring cathedral, fish back, or donut mouthpiece; rough, sharp material; or mechanically altered bits are illegal and shall be cause for disqualification. In all divisions, if a mouth is found to be bloody, disqualification is at the discretion of the judge.
- Roweled spurs.
- Draw reins.
- Excessive schooling.
- Fall of pony or rider.

Set up

- Place two fences on the long diagonal 36ft. / 11m apart
- First fence should be a cross rail set at 24in / 61cm
- Second fence should be a horizontal bar set at 24in / 61cm with a ground pole

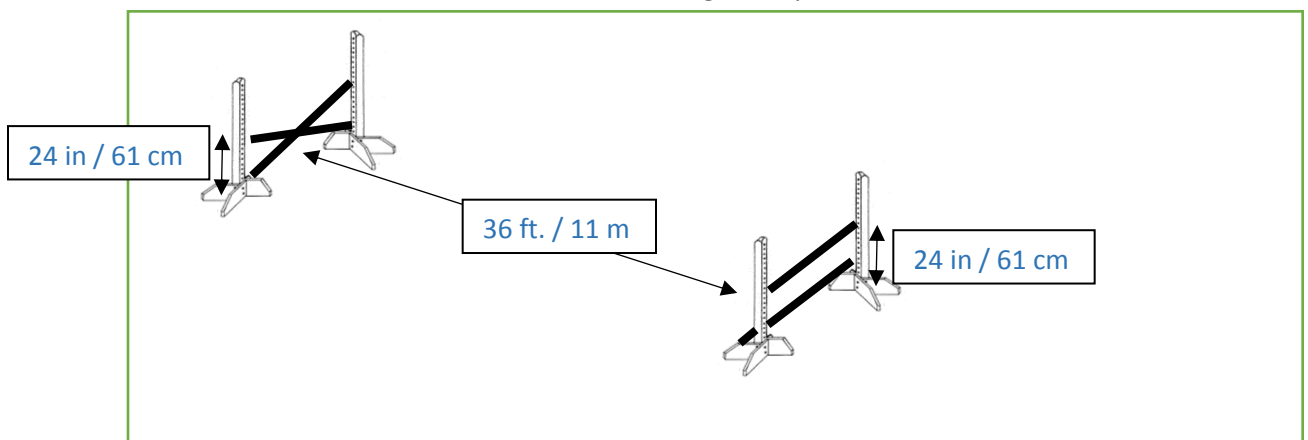

Upload your video

- You have two options: www.youtube.com or www.facebook.com (QPA 2018 Online World Show).
- Name the video you pony's Full Name, 2018 World Show and Class number. For example: A Dash of Dusty 2018 World Show #11 Hunter Hack.
- You may "mute" the video or turn off the sound. Otherwise, do not edit the video in any way.



Quarter Pony Association

2018 On-Line World Show

Submittals Open: May 1, 2018

Entries Close: September 30, 2018

Hunter Hack Open – Rules and Pattern (Class #11)

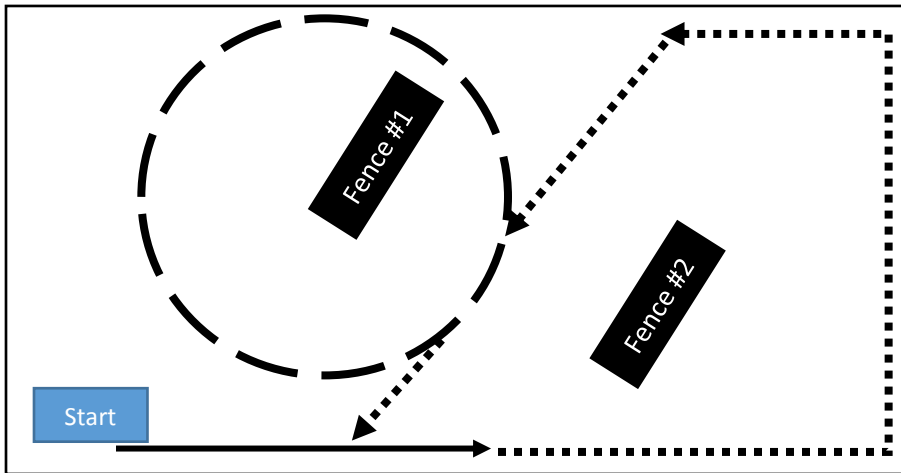

- Start at a halt, acknowledge Judge (camera).
- Walk forward along the rail.
- Pick up the working canter, left lead, around both corners.
- Canter across the long diagonal.
- At center of arena, pick up the working trot.
- Circle right. (Continue next half of pattern below.)

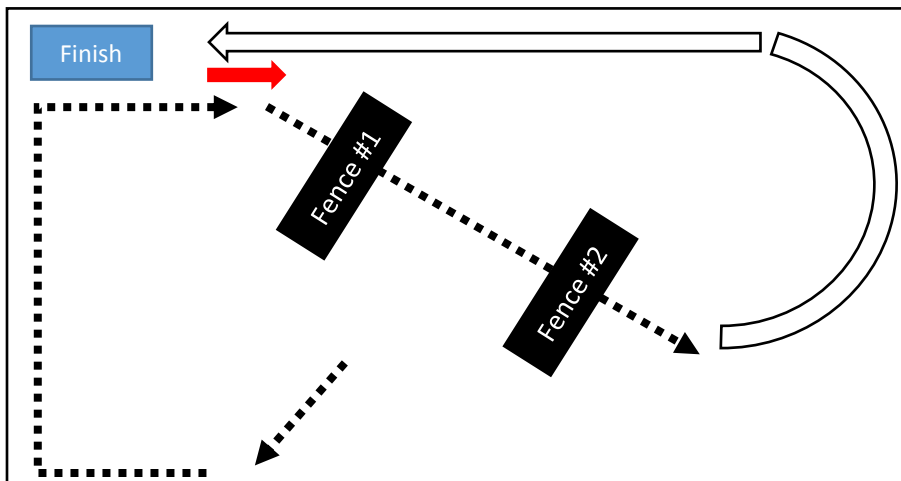

- Pick up the working canter, right lead, around both corners.
- Jump both fences at the canter along the diagonal.
- Pick up the hand gallop, left lead.
- Hand gallop a ½ circle to the left and down the rail.
- Halt on the rail, just past Fence #1.
- Rein back four steps.
- Stand quiet on a loose rein for five seconds, acknowledge Judge (camera).



Quarter Pony Association

2018 On-Line World Show

Submittals Open: May 1, 2018

Entries Close: September 30, 2018

Western Pleasure – Rules and Patterns (Classes #12 -#13)

The ideal pleasure pony should carry its head in a position that is normal for a quarter type pony and no lower than level. Ponies are to be shown on a loose rein without undue restraint. The western pleasure pony should be a pleasure to ride and a free, natural mover. Ponies are to be shown at a walk, jog and lope both ways of the ring. Ponies shall back in a straight line. They shall not be asked to extend the lope. The pony should show a relaxed but collected gait, cadence. The speed should be relaxed and slow, along with calm and responsive disposition.

Judging

- The class is judged on the pony only, 60% on performance, 30% on conformation and 10% on overall appearance and cleanliness of pony and rider.
- Faults to be scored according to severity:
 - Quick, short, or vertical strides or excessive speed.
 - Being on the wrong lead.
 - Breaking gait or pony not responding to requested change of gait in a timely manner.
 - Head carried too high (minor fault) or too low (major fault); or over flexing or straining neck in head carriage so the nose is carried behind the vertical or excessive nosing out.
 - Rider maintaining excessive contact with pony's mouth.
 - Stumbling.
 - Pony appearing sullen, dull, lethargic, emaciated, drawn or overly tired. Excessive tail wringing or ears pinned back.
 - Poor equitation / appointments.

Tack

- Stock-type saddles shall be used without tapaderos.
- Silver mounted equipment is not to count over a good working outfit.

Bits

- Junior ponies (five and under) may be ridden in a snaffle or bosal. Senior ponies (six and older) must be ridden in a shanked bit with one hand on the reins.
- Optional equipment are reatas or lariats and hobbles.
- References to a bit in western performance classes mean the use of a curb bit that has a solid or broken mouthpiece, has shanks and acts with leverage. All curb bits must be free of mechanical device and should be considered a standard western bit. A description of a legal, standard western bit includes:
 - 8-1/2" (21.6 cm) maximum length shank to be measured as indicated in the diagram. Shanks may be fixed or loose.
 - Bars must be round, oval or egg shaped, smooth and unwrapped metal of 5/16" to 3/4" (0.8 cm to 2 cm) in diameter, measured 1" (2.5 cm) from the cheek. They may be inlaid, but must be smooth or latex wrapped. Nothing may protrude below the mouthpiece (bar), such as extensions or prongs on solid mouthpiece.
 - A three-piece bit, with a connecting ring of 1-1/4" (3.2 cm) or less in diameter, or a connecting flat bar of 3/8" to 3/4" (1 cm to 2 cm) measured top to bottom with a maximum length of 2" (5 cm), which lies flat in the pony's mouth is acceptable.
 - The port must be no higher than 3-1/2" (8.9 cm) maximum, with rollers and covers acceptable. Broken mouthpieces, half breeds are standard.
 - 4. Prohibited bits: Slip or gag bits, spades, and donut and flat polo mouthpieces are not acceptable.
 - Reins should be split rein style. Round reins not acceptable in Western Classes.

- Junior Pony (Five and under)
 - Exhibitors are allowed to show with a bosal or snaffle bit. If using one of these, the exhibitor is allowed to use 2 hands on the reins.
- All other western exhibitors are expected to only have one hand on the reins, and may only have one finger between the reins.
- The spare hand must be inconspicuously placed, but close enough to reach the reins easily in case of emergency.
- Resting on the thigh, on the lower stomach, or in that vicinity are all acceptable, but should never touch the saddle or pony.

Upload your video

- You have two options: www.youtube.com or www.Facebook.com (QPA 2018 Online World Show).
- Name the video you pony's Full Name, 2018 World Show and Class number. For example: Texas Thunderbird 2018 World Show #12 Western Pleasure.
- You may "mute" the video or turn off the sound. Otherwise, do not edit the video in any way.

Patterns:

Class #12 – Western Pleasure Jr. Pony

Class #13 – Western Pleasure Sr. Pony

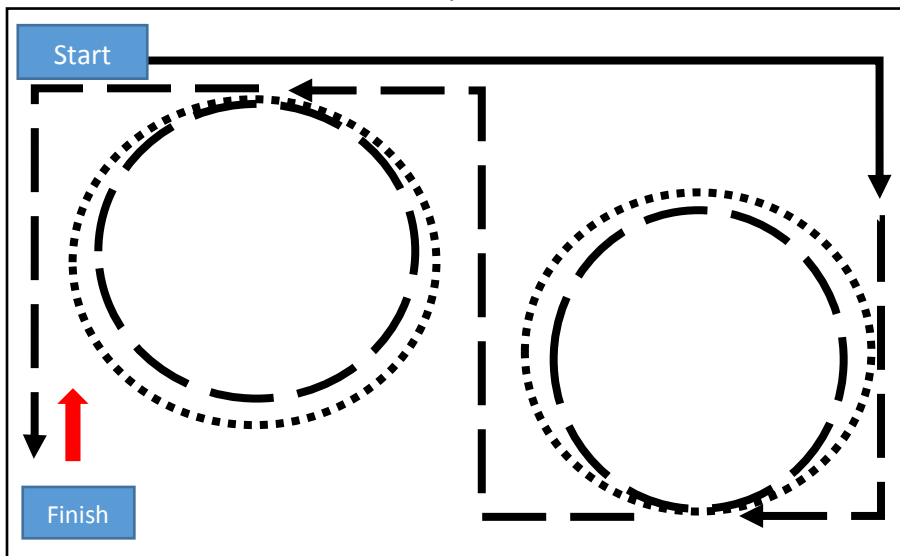

- Start at halt, acknowledge Judge (camera).
- Walk forward along rail and around corner.
- Pick up jog and jog around corner.
- Circle right.
- Pick up lope and circle right.
- Return to jog, turn right, cross arena and turn left.
- Circle left.
- Pick up lope and circle left.
- Return to jog and jog around corner.
- Halt, back one pony length.
- Acknowledge Judge (camera).



Quarter Pony Association

2018 On-Line World Show

Submittals Open: May 1, 2018

Entries Close: September 30, 2018

Western Equitation – Rules and Patterns (Classes #14 -#15)

Rider to be judged on seat, hands, performance of pony, appointments of pony and rider and suitability of pony to rider. Good hands are paramount. Results as shown by the performance of the pony are NOT to be considered more important than the method used in obtaining them.

Judging

- This class will be judged 70% on Equitation and performance; and 30% on appointments.
- Ponies to be:
 - Shown at a walk, jog and lope.
 - Back easily and stand quietly.
 - Extended jog & canter may be added based on Class Type.
- Faults to be scored according to severity:
 - Quick, short, or vertical strides or excessive speed.
 - Being on the wrong lead.
 - Breaking gait or failure to take the appropriate gait when called for.
 - Head carried too high or too low. (Too low is a major fault/Too high is minor fault.) Over flexing or straining neck in head carriage so the nose is carried behind the vertical. Excessive nosing out.
 - Poor equitation

Tack

- Stock-type saddles shall be used without tapaderos.
- Silver mounted equipment is not to count over a good working outfit.

Bits

- Junior ponies (five and under) may be ridden in a snaffle or bosal. Senior ponies (six and older) must be ridden in a shanked bit with one hand on the reins.
- Optional equipment are reatas or lariats and hobbles.
- References to a bit in western performance classes mean the use of a curb bit that has a solid or broken mouthpiece, has shanks and acts with leverage. All curb bits must be free of mechanical device and should be considered a standard western bit. A description of a legal, standard western bit includes:
 - 8-1/2" (21.6 cm) maximum length shank to be measured as indicated in the diagram. Shanks may be fixed or loose.
 - Bars must be round, oval or egg shaped, smooth and unwrapped metal of 5/16" to 3/4" (0.8 cm to 2 cm) in diameter, measured 1" (2.5 cm) from the cheek. They may be inlaid, but must be smooth or latex wrapped. Nothing may protrude below the mouthpiece (bar), such as extensions or prongs on solid mouthpiece.
 - A three-piece bit, with a connecting ring of 1-1/4" (3.2 cm) or less in diameter, or a connecting flat bar of 3/8" to 3/4" (1 cm to 2 cm) measured top to bottom with a maximum length of 2" (5 cm), which lies flat in the pony's mouth is acceptable.
 - The port must be no higher than 3-1/2" (8.9 cm) maximum, with rollers and covers acceptable. Broken mouthpieces, half breeds are standard.
 - 4. Prohibited bits: Slip or gag bits, spades, and donut and flat polo mouthpieces are not acceptable.
 - Reins should be split rein style. Round reins not acceptable in Western Classes.

Exhibitor

- Rider to be judged on seat, hands, performance of pony, appointments of pony and rider and suitability of pony to rider. Good hands are paramount. Results as shown by the performance of the pony are NOT to be considered more important than the method used in obtaining them.

Head

- The rider's head should be held with the chin level and the eyes forward, and may be directed slightly toward the direction of travel. Excessive turning of the head to the inside of the circle, or down at the pony's head or shoulders will be penalized.

Hands

- Both arms should be held in a relaxed, easy manner, with the upper arms in a straight line with the body. The one holding the reins should be bent at elbow forming a line from the elbow to the pony's mouth. Hand to be around reins. When reins are in the left hand and the ends of split reins fall on the near side, or when using the right hand and the ends of split reins fall on the off side, one finger between the reins is permitted. When using a romal or when ends of split reins are held in hand not used for reining, no finger between reins is allowed.
- The free arm may be carried bent at the elbow in a similar position as the hand holding the reins or straight down at the rider's side. It should be kept free of pony and equipment, and excessive pumping or stiffness will be penalized. Rider may hold romal or end of split reins to keep from swinging and to adjust the position of the reins, provided it is held at least 16" from the reining hand. The rider's wrist is to be kept straight and relaxed, with the hand held at about 30 to 45 degrees inside the vertical. The rein hand should be carried immediately above or slightly in front of the saddle horn.
- The reins should be adjusted so that the rider has light contact with the pony's mouth, and at no time shall reins require more than a slight hand movement to control the pony. Excessively tight or loose reins will be penalized.
- Two hands may be used if riding a Junior pony with a snaffle bit or bosal.

Basic Position

- The rider should sit in the saddle in an upright position with the upper body at all gaits. The rider's back should be flat, relaxed and supple. An overly stiff/or overly arched lower back will be penalized. The shoulders should be back, level, and square. The rider's base of support should maintain secure contact with the saddle from the seat to the inner thigh.
- The rider should sit in the center of the saddle with the legs hanging to form a straight line from the ear, through the center of the shoulder and hip, touching the back of the heel or through the ankle.
- The heels should be lower than the toes, with a slight bend in the knee and the lower leg should be directly under the knee. The feet should be in the stirrups with weight on the ball of the foot. The rider's toes should be pointing straight ahead or slightly turned out with the ankles straight or slightly broken in.
- Light contact should be maintained with the saddle and the pony from the knee to mid-calf.

Position in Motion

- Rider should sit to jog and not post.
- Extended jog or canter may be ridden in a hover seat or "two point".
- At the lope, she should be close to the saddle.
- All movements of the pony should be governed by the use of imperceptible aids.
- The shifting of rider's weight is not desirable.
- A rider is penalized if she unintentionally loses a stirrup.

Mounting and Dismounting

- Take up reins in left hand and place hand on pony's neck in front of the withers and with end of reins or romal on the near side. Grasp stirrup with right hand, place left foot in stirrup, then grasp saddle horn with right hand and mount. If a romal is used, it should be moved to the off side of pony after mounting. End of split reins should remain on same side as hand holding the reins when rider uses finger between reins.
- To dismount, reverse the above procedure and step down looking towards the pony's head.

Attire

- Exhibitors must be neatly dressed in western clothes consisting of western boots, western hat OR approved protective headgear (meeting ASTM/SEI safety standards), long-sleeved shirt with a collar, and long pants.
- Spurs, chaps, vests and coats are optional.
- Hunt seat-type safety helmets used in western classes or protective vests (meeting ASTM/SEI standards) shall not be discriminated against.



Quarter Pony Association

2018 On-Line World Show

Submittals Open: May 1, 2018

Entries Close: September 30, 2018

Western Equitation – Rules and Patterns (Classes #14 -#15)

Class #14 – Western Equitation Youth 17 & Under

Class #15 – Western Equitation Adult 18 & Over

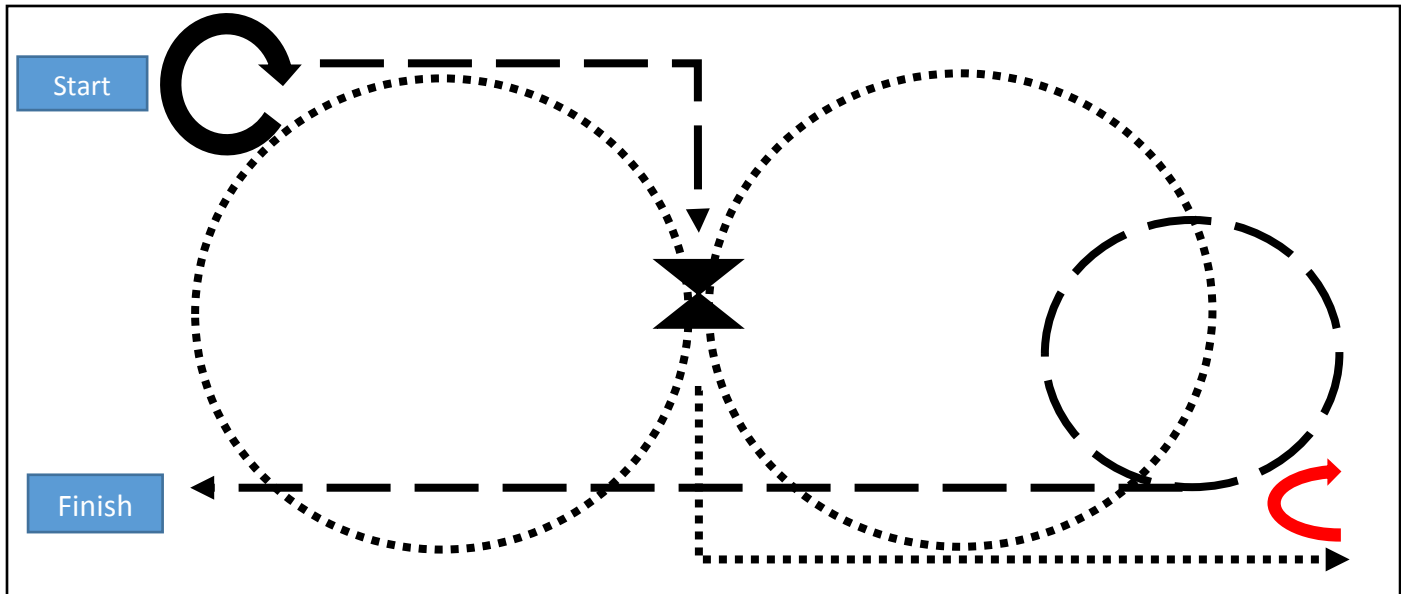

- Start at halt, acknowledge Judge (camera).
- Perform 360* right haunch turn.
- Proceed at the jog, turn right near center of arena.
- Lope a circle to the right (right lead).
- Perform a change of lead – highest points given to a flying change, no penalty for simple or interrupted change, if performed correctly.
- Lope a circle to the left (left lead).
- Proceed straight to rail, turn left, lope towards rail and halt.
- Back pony ½ circle.
- Jog a small circle to the right.
- Proceed straight, drop stirrups and extend jog.
- Halt facing the rail and collect stirrups.
- Dismount, address your pony and acknowledge Judge (camera).

Upload your video

- You have two options: www.youtube.com or www.Facebook.com (QPA 2018 Online World Show).
- Name the video you pony's Full Name, 2018 World Show and Class number. For example: CLR Shesa Bonita 2018 World Show #15 Western Equitation.
- You may "mute" the video or turn off the sound. Otherwise, do not edit the video in any way



Quarter Pony Association

2018 On-Line World Show

Submittals Open: May 1, 2018 Entries Close: September 30, 2018

Driving – Rules and Pattern (Class #16)

A pleasure driving pony should carry itself in a natural, balanced position with a relaxed head and neck. Its poll should be level with, or slightly above the level of the withers. Maximum credit should be given to a pony that moves straight, with free movement, manners and a bright expression

Judging

- This class will be judged 80% on the pony's performance and suitability for ensuring a pleasurable drive, with a maximum of 20% on condition and conformation.
- Pony is to be shown at a flat-footed walk, a slow trot, and an extended trot or working trot both ways of the ring.
- Pony should stand quietly and back readily.
- Manners and quality of the performance will be judged.
- An adult may accompany any Youth (17 & under), but should not take the reins unless necessary to control the pony or to prevent an accident.

Penalties

- The pony shall be severely penalized if it carries its head behind the vertical, is over-flexed, excessively nosed out, the poll is below the withers or exhibits lack of control by exhibitor.
- Extreme speed, high action and breaking gait is to be penalized.
- Set tails, gingering and extreme over-checking result in disqualification.

Tack / Equipment

- Any suitable two or four wheeled vehicle is permitted.
- Single hitch only (no pairs or four-in-hand teams)
- Any suitable single harness is acceptable.
- A snaffle bit with overcheck or a snaffle bit or Liverpool bit with side checks will be considered proper.
- All equipment is to be clean, neat and in sound condition.

Optional Tack

- Running martingales, Overchecks, Blinkers / Blinders, Driving whip, Header

Attire

- Attire should be neat and workmanlike.
- Standard Western or English Attire is acceptable.
- If the exhibitor is a female attired in a short dress, a lap robe is required.
- Head cover such as a Western hat or English Helmet. Driving hats are also acceptable

Optional Attire

- Gloves
- Lap Rug



Quarter Pony Association

2018 On-Line World Show

Submittals Open: May 1, 2018

Entries Close: September 30, 2018

Driving – Rules and Pattern (Class #16)

Pattern (Rail work only, total video should be 5 – 7 minutes)

- Start anywhere on the rail at a relaxed halt, with Header – if needed. Acknowledge Judge (camera) and dismiss Header.
- Proceed at the walk for approximately 30 – 45 seconds.
- Pick up the working trot for approximately 30 – 45 seconds.
- Collect the trot / jog for approximately 30 – 45 seconds.
- Walk and reverse on the long diagonal.
- Proceed at the walk for approximately 30 seconds.
- Pick up the working trot for approximately 30 – 45 seconds.
- Collect the trot / jog for approximately 30 – 45 seconds.
- Collected trot or jog into the center of the arena and halt (Header may join you.)
- Back 6 – 8 steps and close your back.
- Acknowledge Judge (camera).

Upload your video

- You have two options: www.youtube.com or www.Facebook.com (QPA 2018 Online World Show).
- Name the video you pony's Full Name, 2018 World Show and Class number. For example: Smokin Doubledutch 2018 World Show #16 Driving.
- You may "mute" the video or turn off the sound. Otherwise, do not edit the video in any way.



Quarter Pony Association

2018 On-Line World Show

Submittals Open: May 1, 2018

Entries Close: September 30, 2018

Trail –In Hand and Riding Rules and Patterns (Classes #17 -#18)

Judging

This class will be judged on the performance of the pony over obstacles, with an emphasis on manners and response to exhibitor. Credit will be given to ponies negotiating the obstacles with style, without hesitancy, and to ponies showing the capability of picking their own way through the course when obstacles warrant it, and willingly responding to the exhibitor's cues on more difficult obstacles. Ponies shall be penalized for any unnecessary delay while approaching the obstacles. Ponies with artificial appearance over obstacles should be penalized.

The Trail Exhibitor

- Riders / Handlers may exhibit in either Western or English attire.
- Please see English Pleasure / Western Pleasure for the appropriate attire.

In-Hand Trail: This class is designed to provide exhibitors an event to showcase ponies too young to show in performance events. Requirements are created to prepare the young pony for a productive performance career without harming them physically or mentally. This class is available only to weanlings and yearlings.

Tack

- Ponies must be shown in a leather halter, regular or show type is acceptable.
- The lead shank may be a regular type or show type.
- Shank may have a chain, which may be used over the nose, under the chin or through the lead ring on the halter and snapped back to the chain next to the lead strap. Lip chains are strictly forbidden.
- No other tack, including bridles or saddles are permitted.

Performance

- Pony is to be led through the course with the exhibitor on the left side.
- The exhibitor should be positioned between the eye and the mid-point of the neck.
- Exhibitor may change sides to negotiate obstacles, but must change back before proceeding to the next obstacle.

Riding Trail

Tack

- Ponies may be exhibited in either English or Western tack. Please see English Pleasure Tack and / or Western Pleasure Tack for the list of acceptable appointments.

Performance

- Pony is to be ridden through, at least, six obstacles designed to show the walk, trot/jog, canter/lope.
- Obstacles are not to be so difficult as to set up for failure.

Faults / Disqualifications (Both Riding and In-Hand)

- Not doing the obstacles in the prescribed order, missing, failing to complete or not attempting an obstacle.
- Failure to be in prescribed gait or on correct lead.
- Illegal equipment.
- Willful abuse.
- Major disobedience: rearing, schooling, etc.
- Poor Equitation and / or Horsemanship.
- Fall of pony or exhibitor.
- See also English Pleasure / Western Pleasure



Quarter Pony Association

2018 On-Line World Show

Submittals Open: May 1, 2018

Entries Close: September 30, 2018

Trail –In Hand and Riding Trail Rules and Patterns (Classes #17 -#18)

Class #17 – In Hand Trail Weanlings & Yearlings

Equipment Needed:

- Six Poles, at least six feet long.
- Three cones, or physical markers of some kind (buckets, cups, etc.)
- A bucket of some kind (feed pan, bowl, etc.)
- A hoof pick.
- Cones and poles should have approximately 4 feet (1.2 meters) between them.
- Box should be approximately 12 feet (4 meters) square.

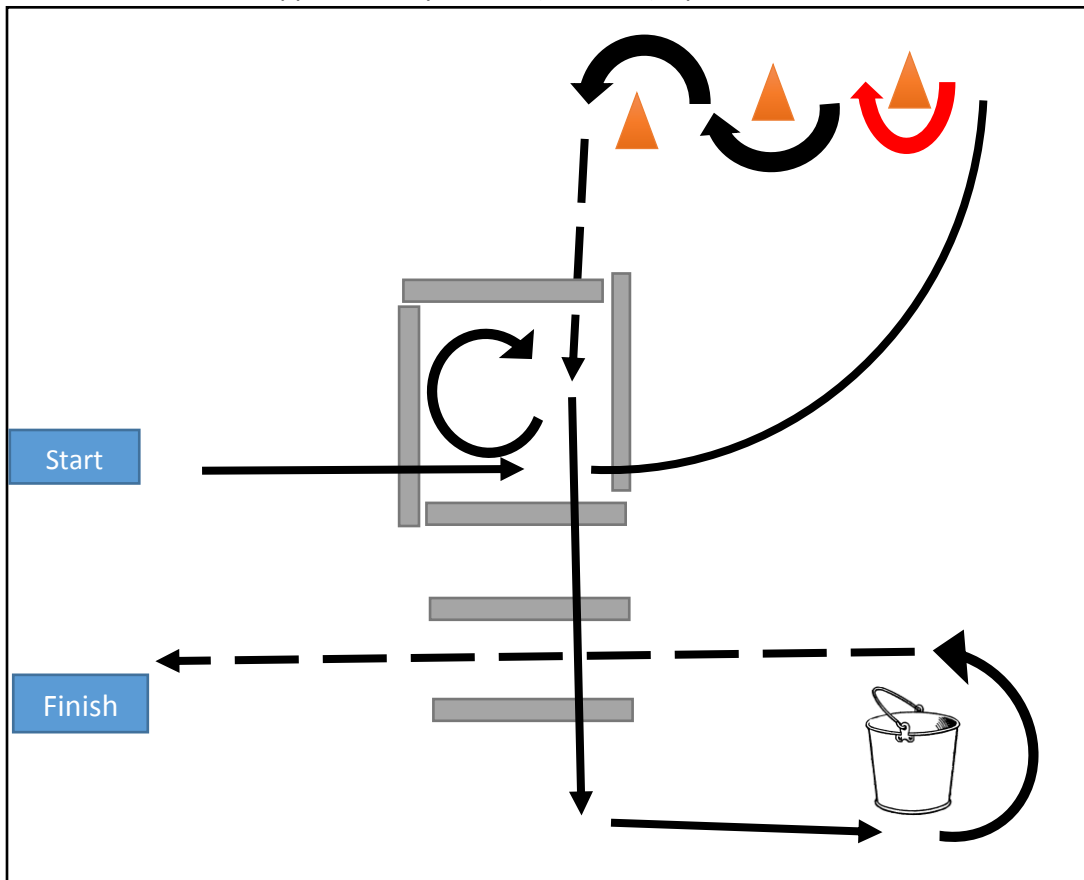

Pattern

- Start at halt, acknowledge Judge (camera).
- Walk through box to first cone.
- Back ½ way around first cone.
- Walk forward weaving the remaining cones.
- Trot into box and halt.
- Perform a 360* right turn.
- Walk out of box, over poles and stop at bucket.
- Take hoof pick out of bucket and clean left fore.
- Walk around bucket and pick up trot.
- Trot through poles.
- Halt, acknowledge Judge (camera).

Upload your video

- You have two options: www.youtube.com or www.Facebook.com (QPA 2018 Online World Show).
- Name the video you pony's Full Name, 2018 World Show and Class number. For example: CL Crescent Power 2018 World Show #17 Trail In Hand.
- You may "mute" the video or turn off the sound. Otherwise, do not edit the video in any way



Quarter Pony Association

2018 On-Line World Show

Submittals Open: May 1, 2018

Entries Close: September 30, 2018

Trail –In Hand and Riding Rules and Patterns (Class #18)

Class #18 – Riding Trail

Equipment Needed:

- Six Poles, at least six feet long.
- Three cones, or physical markers of some kind (buckets, cups, etc.)
- A bucket of some kind (feed pan, bowl, etc.)
- A hoof pick.
- Cones and poles should have approximately 4 feet (1.2 meters) between them.
- Box should be approximately 12 feet (4 meters) square.

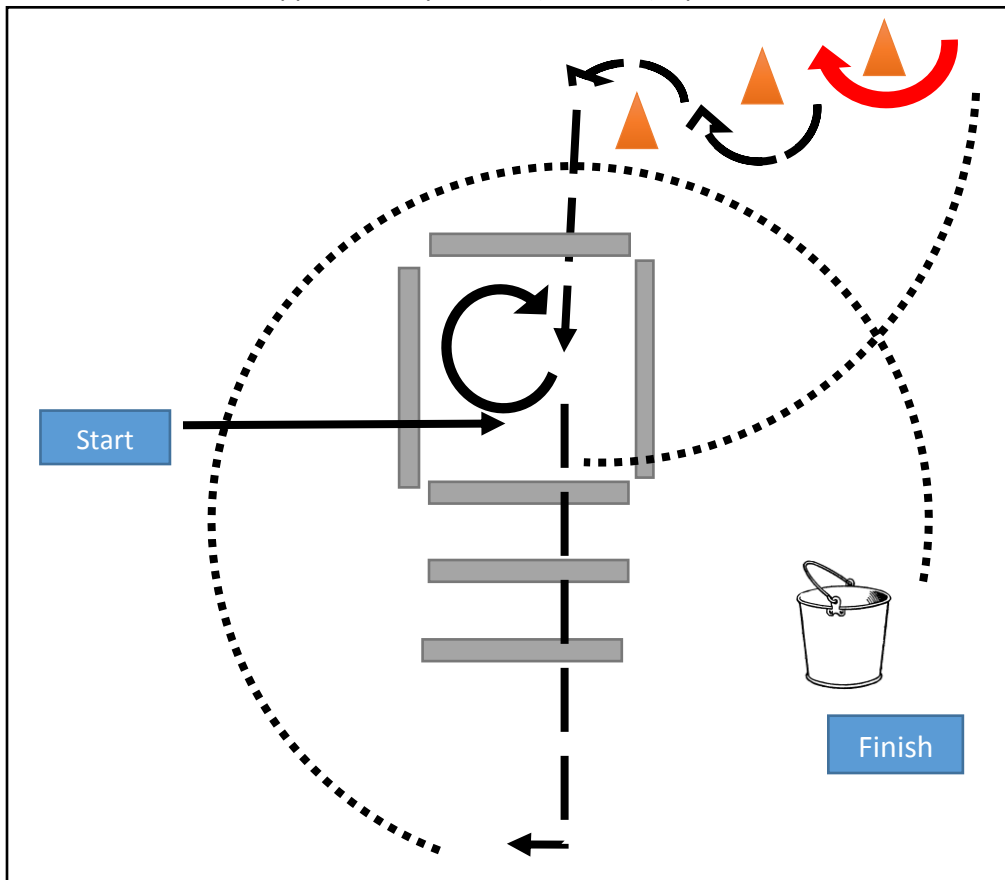

Pattern

- Start at halt, acknowledge Judge (camera).
- Walk into box. Left lead lope / canter out of box to first cone.
- Back ½ way around first cone.
- Jog / Trot forward weaving the remaining cones.
- Jog / Trot into box and halt.
- Perform a 360* right turn.
- Jog / Trot out of box and over poles.
- Right lead Lope / Canter to bucket.
- Dismount
- Take hoof pick out of bucket and clean left fore.
- Acknowledge Judge (camera).

Upload your video

- You have two options: www.youtube.com or www.Facebook.com (QPA 2018 Online World Show).
- Name the video you pony's Full Name, 2018 World Show and Class number. For example: Cody's Fighting Girl 2018 World Show #18 Trail.
- You may "mute" the video or turn off the sound. Otherwise, do not edit the video in any way